

NSPSS

SMA to SMA

Features:
* Broadband

Applications:
* Any Applications

Electrical

Frequency:	DC~3GHz DC~6GHz (Outline C)
VSWR:	1.2 max.
Insertion Loss:	0.25dB max.
RF Power Transmission:	200W
Dielectric Withstanding Voltage:	2500V RMS, 50Hz, at sea level, min.
Working Voltage (DC):	230V*1
Lightning Surge Current:	20kA
Ground Wire Diameter:	8 mm ² max.
Impedance of Dielectric (Center):	1000MΩ min.
Impedance of Contact (Center):	2mΩ max.
Impedance of Contact (Outer):	2.5mΩ max.
Impedance:	50Ω

[1] Default 230V, available for 90V, 150V, 350V and 600V.

Mechanical

RF Connector:	SMA
Mating Life Cycle:	500 cycles min.
Outer Conductor:	Ternary alloy plated brass
Dielectric:	PTFE
Inner Conductor:	Gold plated brass
Gaskets:	Stainless steel

Environmental

Temperature:	-40~+85°C
Ingress Protection (IP) Rating:	IP 67
Relative Humidity:	95% max. @25°C±2°C

Outline Drawings

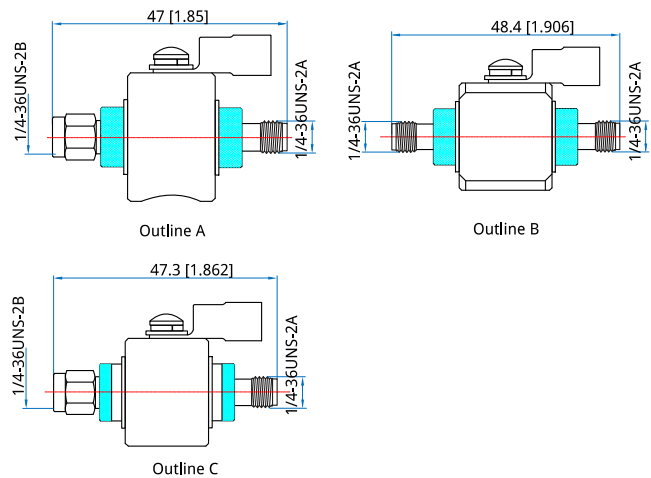

Unit: mm [in]

Tolerance: ±0.2mm [±0.008in]

How To Order

NSPSS-MF-03 - SMA(m) to SMA(f), DC~3GHz, Outline A

NSPSS-FF-03 - SMA(f) to SMA(f), DC~3GHz, Outline B

NSPSS-MF-06 - SMA(m) to SMA(f), DC~6GHz, Outline C

Customization is available upon request.